

# EXspect 231 NIR absorption sensor in compact design



- » Compact design with integrated amplifier and touch display
- » %-turbidity / EBC, FAU / mg/l / AU / OD or customer defined unit
- » Durable sapphire lens
- » Hygienic Design, CIP/SIP-capable
- » LED light source guarantees a durable and stable signal
- » Easy parameterization via display or software EXpert

[EXspect 231](#) is a high-precision NIR compact sensor for monitoring production processes in the food and pharmaceutical industries as well as in many areas of further process applications, which can be optimally adapted to the respective measuring task

## Specifications

Measuring range max.	0-100 % / 0...6 AU / 0...6600 EBC
Resolution	0,1 % or 0,01 AU
Accuracy	± 1 %
Reproducibility	≤ 1 % from final value
Wavelength	850 nm
Light source	LED
Optical path length	5, 10 or 20 mm
Material	Stainless steel 1.4435 (316L)
Surface	e-polished <Ra 0,37 µm
Window	Sapphire
Supply voltage	24 V DC
Contact	NO or NC configurable 150 mA
Input contact	zeroing
Process connection	Thread G1/2"
Process temperature	0 ... 90 °C, 141 °C max. 2 hours (SIP cycle)
Process pressure	max. 10 bar (150 psi)
Electrical connection	M12 connector 5-pin or 8-pin (digital parameterizable)
Cable length	2 m / 5 m
Interfaces	4 ... 20 mA with switching contact
Parameterization	Software EXpert
Protection class	IP69

## Typical Measurements

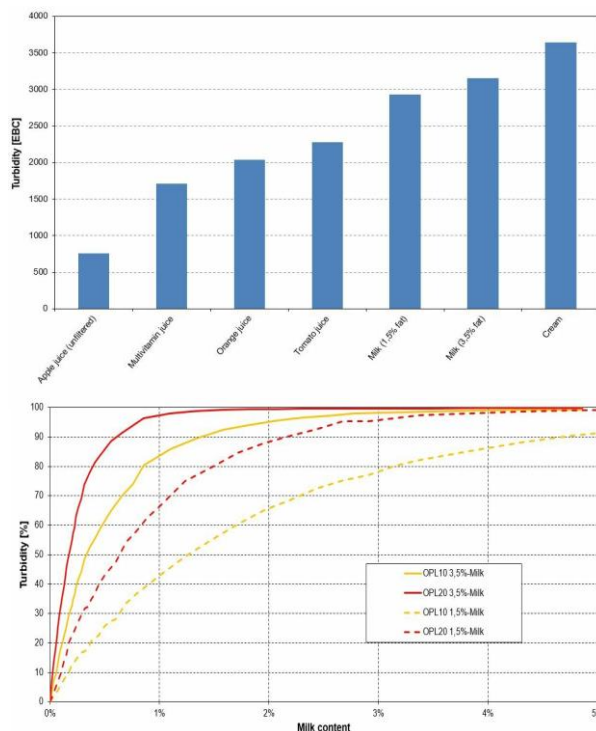

## EXspect 231 NIR absorption sensor in compact design

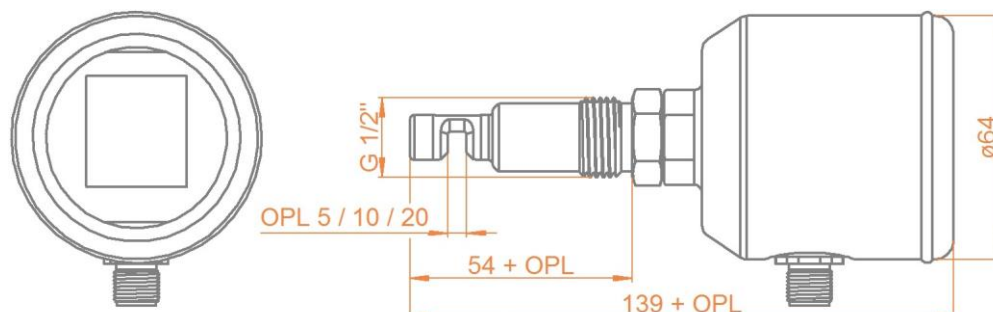

### Ordercode

Code	Measuring range	Delivery
A	0...100% turbidity	3 weeks
B	0...3.5 AU / 0...3850 EBC / 0...7 OD	3 weeks
C	0...6 AU / 0...6600 EBC / 0...12 OD	3 weeks

Code	Optical path length	Delivery
05	5 mm	3 weeks
10	10 mm	3 weeks
20	20 mm	3 weeks

Code	Material (wetted parts)	Delivery
4435	Stainless steel 1.4435 / 316L	3 weeks

Code	Sealing material (wetted sealings)	Delivery
MET	Metal sealing (without elastomer)	3 weeks

Code	Process connection	Delivery
G12	Thread G1/2"	3 weeks

Code	Interface	Delivery
AS	Analogue 4...20 mA / M12 5 pin	3 weeks
AD	Analogue 4...20 mA / digitally parameterizable / M12 8 pin	3 weeks

Code	Display	Delivery
1	With integrated display	3 weeks