

## EXtract 811M stainless steel, extended immersion

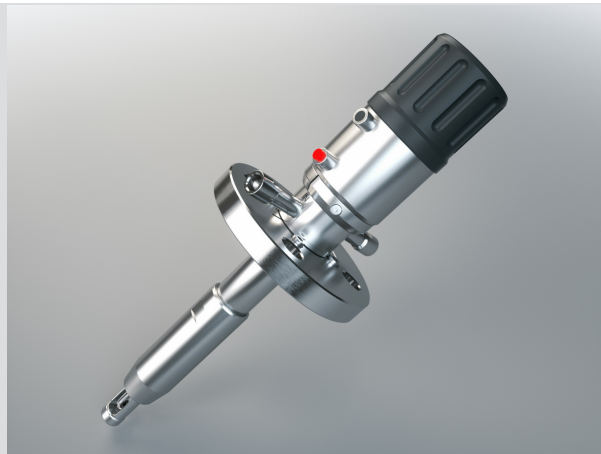

- » Robust design, integrated scraper
- » Automatic locking system with indicators for measurement- and service position
- » Automatic safety lock while sensor is removed
- » Safe handling under higher process pressure due to unique rotary drive
- » Stainless steel AISI 316L / 1.4404 or Alloy
- » Usable in ATEX-areas
- » Immersion length up to 207mm

EXtract 811M is a manual retractable holder made of stainless steel for installation of  $\varnothing 12-325\text{mm}$  sensors on tanks or pipelines with an extended immersion length up to 207mm with an unique rotary drive unit

### Specifications

Process pressure	0...16bar
Process temperature	-10...140°C
Ambient temperature	-10...70°C
Immersion length	up to 207mm
Sensors	$\varnothing 12-325\text{mm}$ PG 13.5
Materials	stainless steel 1.4404 /316L, Alloy C22 (2.4602)
Sealings	EPDM, FPM (Viton), FFKM (Kalrez)
Process connection	Flange DN50 PN16 / DN40 PN16 / ANSI 2" 150lbs / ANSI 1 1/2" 150lbs
Cleaning ports	G1/8", G1/4", FNPT 1/4"
Drive unit	manual rotary drive unit
Limit switches	optional electrical NAMUR switches

### Dimensions

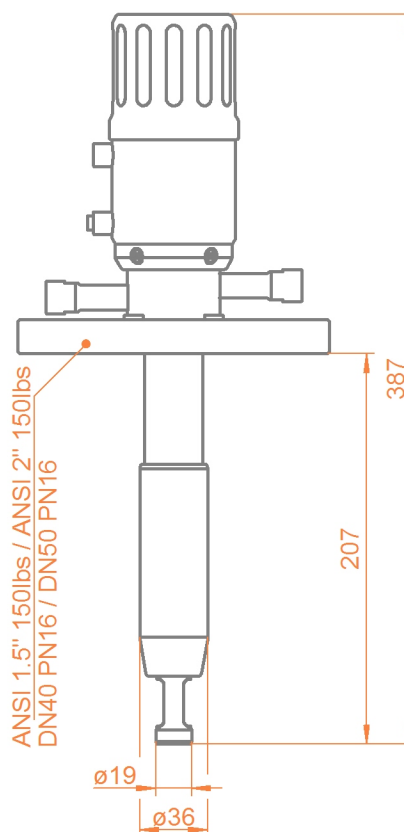

## EXtract 811M stainless steel, extended immersion

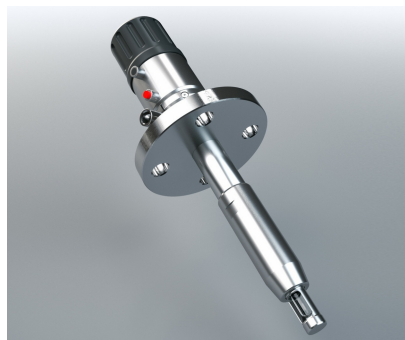

In measuring position with extended sensor window



Rotary drive to overcome higher process pressures



If the armature is in measuring position the sensor can not be removed

### Ordercode

Code	Material (wetted parts)	Delivery
4404	Stainless steel 1.4404 / 316L	2 weeks
HC22	Alloy C22 2.4602	4 weeks

Code	Sealing material (wetted sealings)	Delivery
EPD	EPDM/FDA/USP VI	2 weeks
FPM	FPM (Viton)	2 weeks
FKM	FFKM (Kalrez)	3 weeks

Code	Sensor type	Delivery
325	325mm PG 13,5 gel-filled	2 weeks
380	380mm PG 13,5 liquid filled	2 weeks

Code	Process connection	Delivery
D40	Flange DN40 PN16	2 weeks
D50	Flange DN50 PN16	2 weeks
A12	Flange ANSI 1 1/2" 150lbs	2 weeks
A20	Flange ANSI 2" 150lbs	2 weeks

Code	Cleaning connection	Delivery
G18	G 1/8" female thread	2 weeks
G14	G 1/4" female thread	2 weeks
N14	1/4" NPT female thread	2 weeks

Code	Position switch	Delivery
00	without	2 weeks