

Backscatter TriClamp Process Probe

Applications:

- Interface detection
- Concentration measurement
- Product differentiation & identification
- Control & optimize CIP cycles

The Kemtrak backscatter TriClamp process probe is designed to accurately measure low to extremely high turbidity directly in pipelines. The probe uses a standard DN25/1" TriClamp sanitary type process connection making it suitable for direct mounting on any size pipeline greater than DN25/1" diameter.

The dual fiber optic design of the immersion probe provides high resolution at low turbidity with excellent linearity all the way up to extremely high turbidity when used with a Kemtrak NBP007 near-infrared backscatter photometer.

A unique benefit of the Kemtrak backscatter immersion probe is that it does not go blind at high sample turbidity. Other probes will stop working at 4000 NTU/FNU (<1 wt% solids) after which the signal will decrease resulting in an erroneous and misleading output. The output of the Kemtrak probe will continue to increase with sample concentration ensuring a reliable measurement.

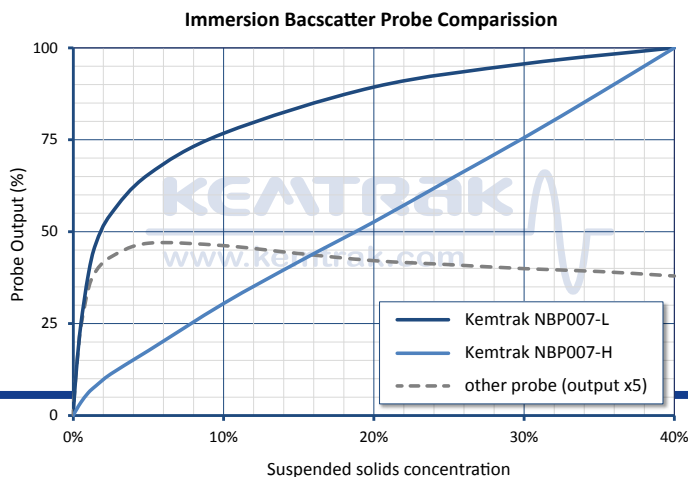

The probe is manufactured in 316L stainless steel with a robust scratch resistant sapphire window. The highly polished unbroken probe surface ensures freedom from fouling and suitability for sanitary applications.

The fiber optic immersion probe has no electronics that will be damaged by high temperature process streams or sterilization cycles and is suitable for hazardous area use.

All Kemtrak products are made from the highest quality materials and are designed to the most demanding specifications to ensure long life and the highest reliability.

KEATRak

www.kemtrak.com

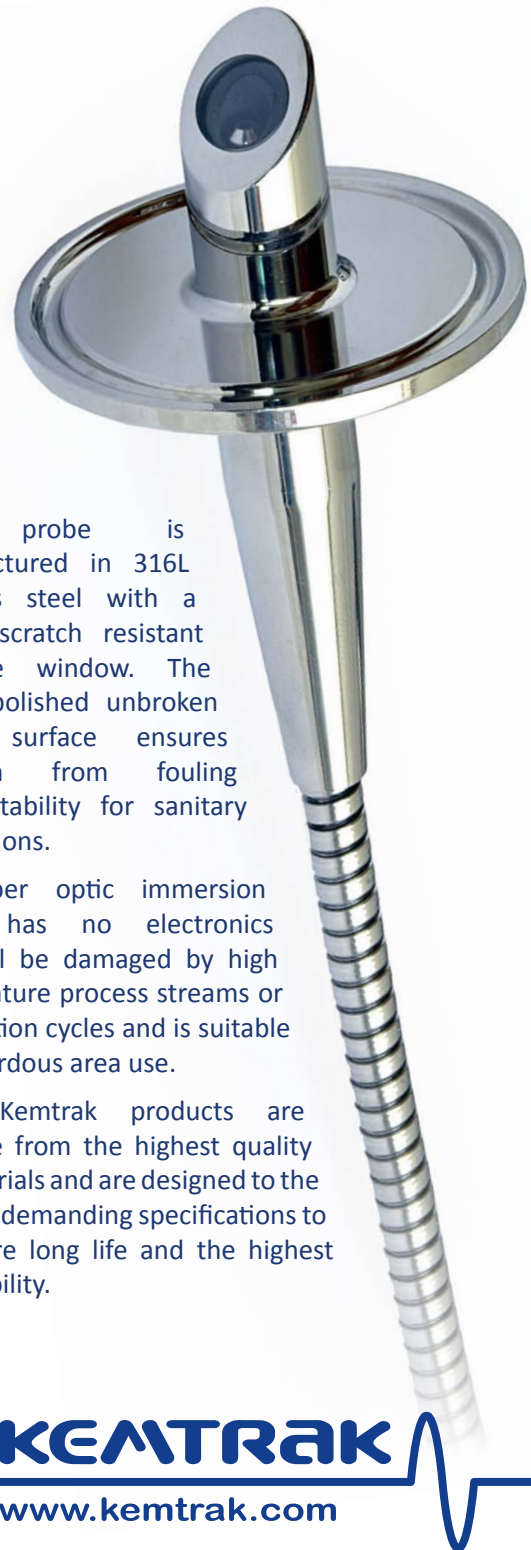



Compatible with
DN 25, DN32, DN40
1" and 1½" pipe clamp fittings

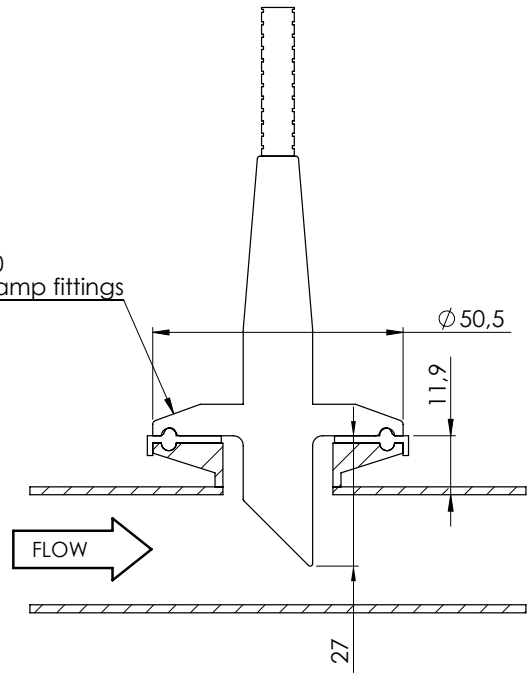

Benefits:

- 5 ... > 4000 FTU (up to 100% solids)
- Standard TriClamp type sanitary fitting (ISO 2852 & DIN 32676)
- Sapphire window is mounted from inside of probe and sealed using o-rings (no epoxy) - impossible to fall out in the process
- Suitable for installation in hazardous area (Ex proof)

Technical Data Backscatter TriClamp Probe

Measurement Range
5 FNU/NTU - 100% solids

Manifold
Sanitary Tri-Clamp® clamp type fitting
ISO 2852 & DIN 32676
Compatible with ± 0.19 mm outside diameter (DN25, DN32, DN40, 1" and 1½").

Material
Stainless EN 1.4435 / 316L

Window
Sapphire

Surface Finish
Ra < 0.4 µm

Elastomers
EPDM (FDA), FKM (FPM, Viton®, Fluorel®), FFKM (Kalrez® Spectrum 6375)

Operating Conditions
Ambient & process temperatures up to 260°C (500°F)
Process pressure from 10 mbar to 16 bar
Operating conditions subject to material and design in use

Fibre Optic cable
Silica core photonic fiber with fully-interlocked flexible stainless steel jacket and Kevlar® reinforcement
Terminated with SMA 905 connectors
Lengths up to 100 m (328 foot)

Protection
IP66 / EN 60529

Recommended Controller
Kemtrak NBP007 backscatter photometer

KEMTRAK
www.kemtrak.com

Kemtrak AB • Box 2940 • SE-187 29 Stockholm • Sweden
Info@kemtrak.com • www.kemtrak.com

*We reserve the right to make changes
without previous notice*

Distributor

www.celld.com
+33 4 66 82 82 60

Kemtrak is a leading manufacturer of fiber optic measuring and automation products for the process engineering industry. The Company provides tailor made solutions to meet the needs of a wide range of industries including chemical, petrochemical & offshore, pharmaceutical, food & beverage, pulp and paper and water & environment. With its headquarters in Stockholm Sweden, Kemtrak has trained representatives and support personnel globally. The main manufacturing facility in Gothenburg, Sweden is certified according to ISO 9001:2000.