

EXstatic 310 thread G1 1/4" for weld-in



- » Designed according to hygienic criteria Surface finish Ra<0,78 or Ra<0,37
- » Stainless steel AISI 316L / 1.4404
- » EPDM sealings with FDA and USP VI approval
- » Optional sensor protection cage
- » Up to 10 bar and 140 °C
- » Protection cap for cable connection

Static sensor holder for permanent installation of Ø12mm/120mm-sensors on welding sockets DN25 in tanks or pipes

Specifications

max. pressure	10 bar
max. temperature	140°C
material	1.4404 / 316L
surface	Ra<0,78 or Ra<0,37
sealing material	EPDM / FDA / USP VI or FPM (Viton)
material cable guard certificates	PA6.6 GF30 material, surface, sealing material
option	with protection cage
sensors	or without

Dimensions

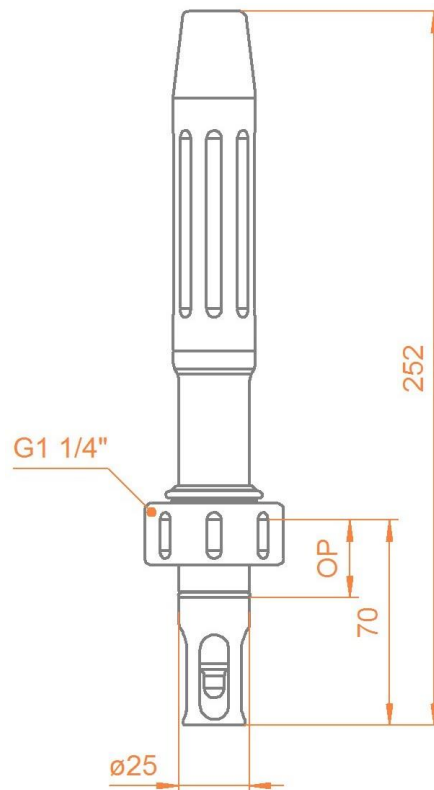

EXstatic 310 thread G1 1/4" for weld-in



Protection cage on EXstatic 310



EXstatic 310 - without protection cage



Installation example: left EXstatic 310, right EXstatic 315

Ordercode

Code	Material (wetted parts)	Delivery
0408	Stainless Steel 1.4404 / 316L Ra0,78	2 weeks
0404	Stainless Steel 1.4404 / 316L Ra0,37	4 weeks

Code	Sealing Material (wetted sealings)	Delivery
EPD	EPDM/FDA/USP VI	2 weeks
FPM	FPM (Viton)	2 weeks

Code	Sensor type	Delivery
120	120mm PG 13,5 Ø12mm	2 weeks

Code	Process Connection	Delivery
IN25	G1 1/4" (DN25) O-ring-position 25mm	2 weeks

Code	Immersion length	Delivery
070	70mm under process connection	2 weeks

Code	Protection cage	Delivery
0	without	2 weeks
1	with protection cage	2 weeks